

Oil Service Units

**UM 045 · UMPC 045**

Oil service - simple, quick and compact · with integrated particle monitor



UM 045



UMPC 045



OPCom Particle Monitor  
(integrated in UMPC)

- › Easy filling, cleaning and pumping over
- › Unbeatable ergonomics, comfortable handling
- › High filtration efficiency
- › Optionally with integrated particle monitor
- › With integrated humidity sensor
- › With automatic switch-off function

Description

**Oil service units**

*Easy, compact and ergonomic*

With the oil service unit UM 045 · UMPC 045, hydraulic or lubrication systems can simply be filled, cleaned or fluid can be transferred without using the filter function. The compact size and ergonomic design allows for easy handling in minimal work spaces.

*Protection of components through ultra-fine filtration*

The EXAPOR®MAX 2 ultra-fine element is the heart of the ARGO-HYTOS oil service unit. A high separation efficiency guarantees excellent cleanliness levels and thereby maximum protection of components. The high dirt holding capacity of the EXAPOR®MAX 2 ultra-fine elements makes the oil service units an economical choice for our customers.

**UM 045**

The UM 045 comes ready to connect, equipped with hoses. For easy transport, the electrical cables, as well as the suction and return hose, are fixed with support fixtures onto the carrier device. Additional tools can be stowed in the basket of the carrier device.

**UMPC 045**

The UMPC may be switched off, based on the cleanliness class. Once the desired value has been reached or fallen below for three consecutive times, the device switches off.

In versions -\*5735, a particle monitor and a humidity sensor are integrated. Here, the particle classes as well as %rH and temperature are output.

In versions -\*5835, a particle monitor and an oil condition sensor are installed. Here, the particle classes %rH, temperature, permittivity and conductivity are issued.

Via a WLAN SD card, data can be transmitted to a computer or a smartphone during measurement. In case data transmission should not be possible, the data is meanwhile stored on the SD card and can be retrieved at a later point in time.

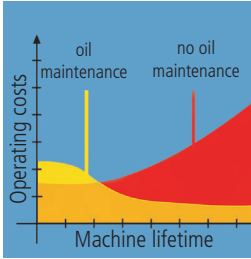

### Economical

The UM 045 Oil Service Units offer protection that can extend the lifetime of machinery. This protection gives a direct return on investment through extended service intervals and increased machine availability.



### User-friendly filter element change

The filter element can be removed from the housing together with the cover. The dirt retention valve ensures that solid particle sediment is completely removed with the filter element.



### Switching functions

The selector valve is used to switch between the basic modes of operation: "filtering" and "pumping over without filtering".



### Keeping hoses in place

The retainers attached to the sides of the frame secure the hoses in any transport position.



### Compact design

Among the numerous advanced features, listed in the specification of the UM units, compact design was a basic requirement to be met by our team of design engineers. Transporting the UM in horizontal position, e.g. in the cargo area of a service vehicle, is facilitated by the wheels and the curved design of the frame.



### Unbeatable ergonomics

Superior technology and excellent design are of no use if the operator can only move the service equipment with great physical effort. Therefore, ergonomics were of primary importance when designing the UM units.

Owing to its optimized weight distribution, the UM can be tilted from the standing position with minimum effort. In the tilted position, the UM can be moved walking upright, removing strain from the back.

**Cleaning speed**

The cleaning speed depends on the efficiency of the filter elements ( $\beta_{x(c)}$ ), the nominal volume flow ( $Q_{\text{nominal}}$ ) and the oil volume ( $V_{\text{actual}}$ ).

In graph D1-D2, the cleaning time is shown in relation to the filter fineness (indication of cleanliness classes according to ISO 4406:1999). The values are recorded by laboratory methods and may be influenced by environmental conditions (e.g. compared to the laboratory test dust ISO MTD considerably deviating particle constellations, continuous additional introduction of dirt on running systems, high water content, etc.).

All characteristic curves (see graphs D1-D2) relate to a **reference oil volume of 180 l / 47.5 gallons** and a **nominal volume flow of 15 l/min / 4 gpm**.

The following formula should be used to convert to the actual oil volume:

$$t_{\text{actual}} = \frac{V_{\text{actual}} \cdot \Delta t}{12 \cdot Q_{\text{nominal}}}$$

- $t_{\text{actual}}$  = actual cleaning speed
- $\Delta t$  = cleaning speed for oil volume of 180 l / 47.5 gallons
- $V_{\text{actual}}$  = volume of oil to be cleaned
- $Q_{\text{nominal}}$  = nominal volume flow, see Selection Chart

For monitoring purposes, we recommend the OPCOM from ARGO-HYTOS, integrated in the version FAPC 016 or the OPCOUNT Particle Counter.

**Determining the cleaning time**

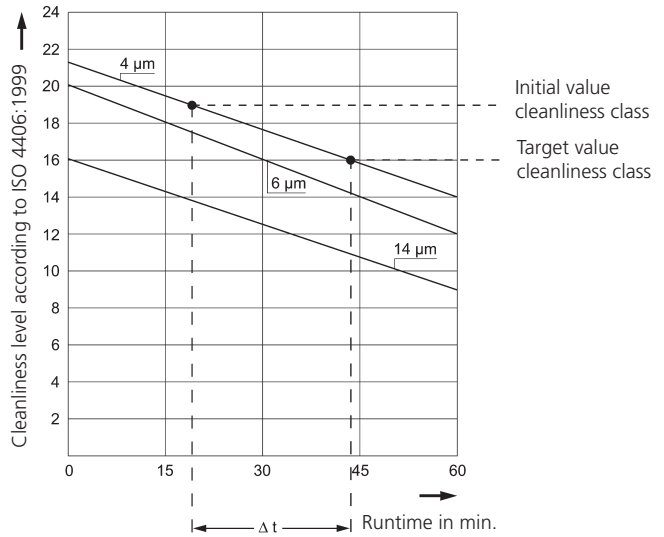

- ▶ Determine the initial cleanliness class and enter it on the graph, e. g. 19/17/14 according to ISO 4406:1999
- ▶ Enter the target cleanliness class on the graph, e.g. 16/14/11 according to ISO 4406:1999
- ▶ Determine  $\Delta t$ , in this case  $\Delta t = 25$  min
- ▶ Insert the value in the formula, where  $V_{\text{actual}} = 350$  l / 92.5 gallons and  $Q_{\text{nominal}} = 16$  l/min / 4.2 gpm

$$t_{\text{actual}} = \frac{V_{\text{actual}} \cdot \Delta t}{12 \cdot Q_{\text{nominal}}} = \frac{350 (92.5) \cdot 25}{12 \cdot 16 (4.2)} \approx 46 \text{ min}$$

**Curves for the cleaning time as a function of the filter fineness**

**D1** 3EN2 and 5EN2 EXAPOR®MAX 2 filter element  
Reference oil volume with  $Q_{\text{Off-line filter}} = 15$  l/min / 4 gpm.

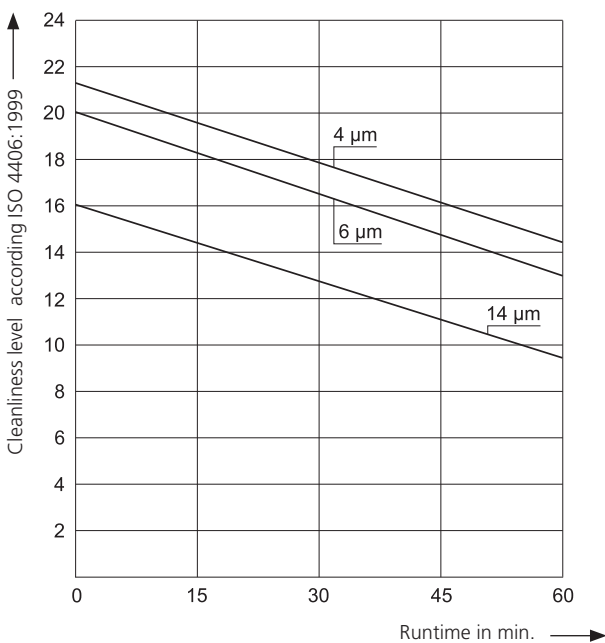

**D2** 10EX2 EXAPOR®MAX 2 filter element  
Reference oil volume with  $Q_{\text{Off-line filter}} = 15$  l/min / 4 gpm.

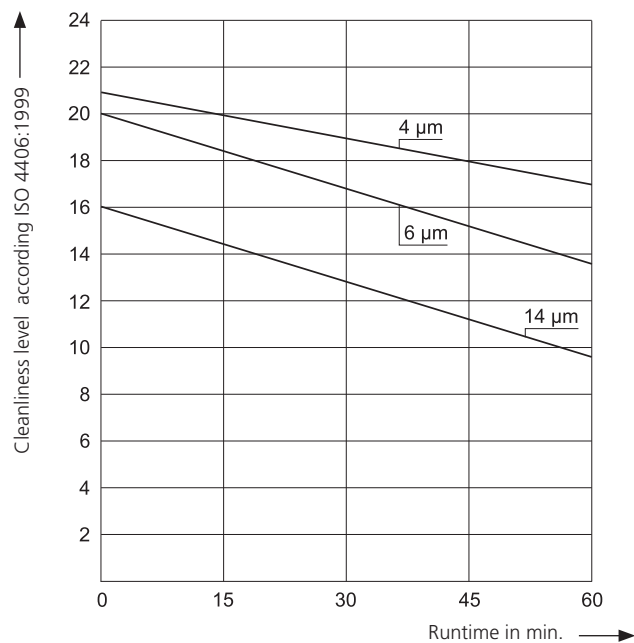

## Filter fineness curves in the selection chart

**Dx** Filtration ratio  $\beta$  as a function of particle size  $x$  obtained by the Multi-Pass-Test according to ISO 16889

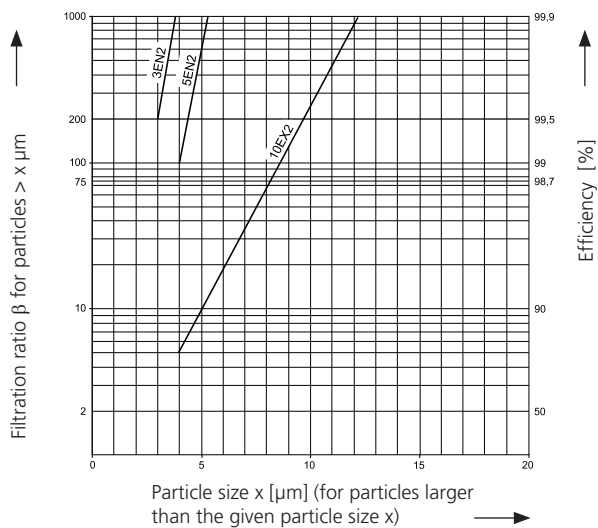

The abbreviations represent the following  $\beta$ -values resp. finenesses:

### For EXAPOR®MAX2 elements:

3EN2 =  $\bar{\beta}_{3(c)} = 200$  EXAPOR®MAX2  
 5EN2 =  $\bar{\beta}_{5(c)} = 200$  EXAPOR®MAX2  
 10EX2 =  $\bar{\beta}_{10(c)} = 200$  EXAPOR®MAX2

## Characteristics

### Hydraulic connection

*Hoses:*

Suction hose NG 32, length 2.7 m / 8.9 ft,  
 with suction strainer 280  $\mu$ m,  
 pressure hose NG 25, length 2.7 m / 8.9 ft.

### Electrical connection / electric motor

*Electric motor, air cooled fan type*

Cable: length 6 m / 19.7 ft  
 Electro motor types: 1 ~ 230 V / 50 Hz  
 3 ~ 400 V / 50 Hz  
 (3 ~ 460 V / 60 Hz)

Protection type: IP 54  
 (see Selection Chart)

### Tank volume

Approx. 13 l / 3.4 gal

### Pump design

Internal gear pump

### Operating and transport position

Operating position: upright  
 Transport position: upright or horizontal

### Hydraulic fluids

Mineral oil and biodegradable fluids  
 (HEES and HETG, see info service sheet 00.20).  
 Other fluids on request.

### Temperature range of fluids

0 °C ... +65 °C / +32 °F ... +149 °F  
 (also see table Viscosity Range)

### Ambient temperature range

0 °C ... +50 °C / +32 °F ... +122 °F

### Accessories

Water-absorbing filter elements EXAPOR®AQUA.  
 These can be used for short-term water absorption in all  
 standard units (on request).

### Viscosity range

Type	Continuous operation min.	Continuous operation max.	Short-term operation max.
UM 045	15 mm <sup>2</sup> /s / 70 SUS	600 mm <sup>2</sup> /s / 2790 SUS	800 mm <sup>2</sup> /s / 3720 SUS
UMPC 045	15 mm <sup>2</sup> /s / 70 SUS	250 mm <sup>2</sup> /s* / 1160 SUS* 600 mm <sup>2</sup> /s* / 2790 SUS*	800 mm <sup>2</sup> /s / 3720 SUS

\* An exact measurement of the oil cleanliness class is only possible within a viscosity range from 15 mm<sup>2</sup>/s to 250 mm<sup>2</sup>/s / 70 SUS to 1160 SUS.

## Dimensions

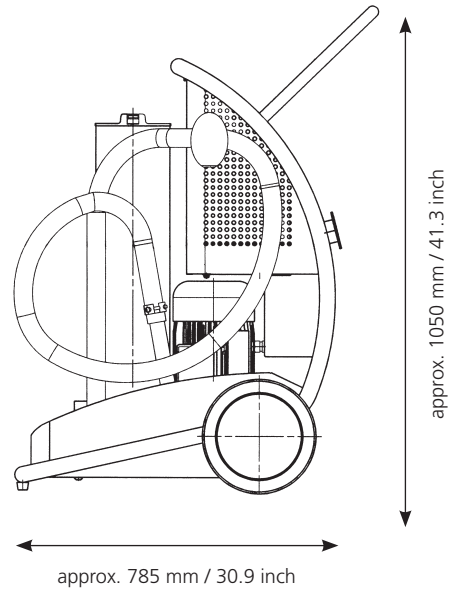
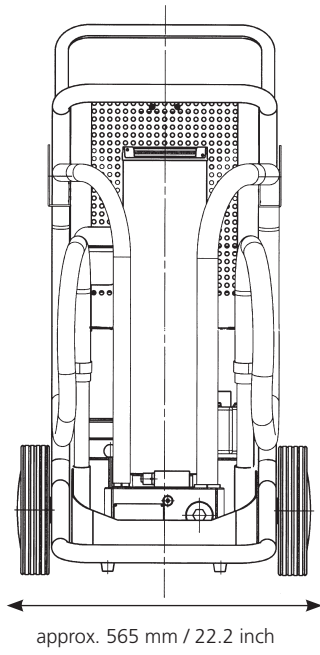

## Hydraulic symbol - UM 045

1

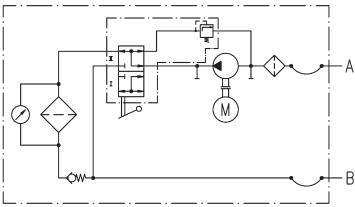

## Hydraulic symbol - UMPC 045

2

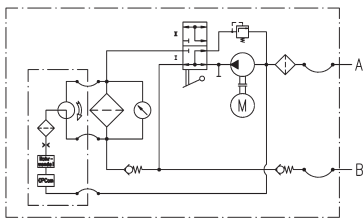

## Selection Chart

Order No.	Nominal flow rate	Filter fineness see diagram <b>Dx</b>	Dirt holding capacity	E-Motor operating voltage	E-Motor max. operating frequency	E-Motor power	Length suction hose (lance incl.)	Length pressure hose (lance incl.)	Viscosity	Suction height max.	Hydraulic symbol	Replacement element order no.	Clogging indicator	Weight
<b>Basic model – UM 045</b>														
UM 045-1553	45 l/min** 11.9 gpm**	3EN2	1950 g	1~230 V	50/60Hz	1.1 kW**	2.7 m / 8.9 ft	15 ... 600 mm <sup>2</sup> /s 70 ... 2790 SUS	2.0 m 6.6 ft	1	V7.1560-103	optical	76.5 kg 169 lbs	
UM 045-4553	45 l/min** 11.9 gpm**	3EN2	1950 g	3~400V 50Hz 3~460V 60Hz	50/60Hz	1.1 kW**	2.7 m / 8.9 ft	15 ... 600 mm <sup>2</sup> /s 70 ... 2790 SUS	2.0 m 6.6 ft	1	V7.1560-103	optical	76.5 kg 169 lbs	
UM 045-1153	45 l/min** 11.9 gpm**	5EN2	1980 g	1~230 V	50/60Hz	1.1 kW**	2.7 m / 8.9 ft	15 ... 600 mm <sup>2</sup> /s 70 ... 2790 SUS	2.0 m 6.6 ft	1	V7.1560-03	optical	76.5 kg 169 lbs	
UM 045-4153	45 l/min** 11.9 gpm**	5EN2	1980 g	3~400V 50Hz 3~460V 60Hz	50/60Hz	1.1 kW**	2.7 m / 8.9 ft	15 ... 600 mm <sup>2</sup> /s 70 ... 2790 SUS	2.0 m 6.6 ft	1	V7.1560-03	optical	76.5 kg 169 lbs	

<b>UM with integrated Particle Monitor OPCom – UMPC 045</b>														
UMPC 045-15735 ***	45 l/min** 11.9 gpm**	3EN2	1950 g	1~230 V	50/60Hz	1.1 kW**	2.7 m / 8.9 ft	15 ... 600 mm <sup>2</sup> /s 70 ... 2790 SUS	2.0 m 6.6 ft	2	V7.1560-103	electr.	97 kg 214 lbs	
UMPC 045-15835 ****	45 l/min** 11.9 gpm**	3EN2	1950 g	1~230 V	50/60Hz	1.1 kW**	2.7 m / 8.9 ft	15 ... 600 mm <sup>2</sup> /s 70 ... 2790 SUS	2.0 m 6.6 ft	2	V7.1560-103	electr.	97 kg 214 lbs	
UMPC 045-45735 ***	45 l/min** 11.9 gpm**	3EN2	1950 g	3~400V 50Hz 3~460V 60Hz	50/60Hz	1.1 kW**	2.7 m / 8.9 ft	15 ... 600 mm <sup>2</sup> /s 70 ... 2790 SUS	2.0 m 6.6 ft	2	V7.1560-103	electr.	97 kg 214 lbs	
UMPC 045-45835 ****	45 l/min** 11.9 gpm**	3EN2	1950 g	3~400V 50Hz 3~460V 60Hz	50/60Hz	1.1 kW**	2.7 m / 8.9 ft	15 ... 600 mm <sup>2</sup> /s 70 ... 2790 SUS	2.0 m 6.6 ft	2	V7.1560-103	electr.	97 kg 214 lbs	

Please request our data sheet no. 100.10 for more detailed information on the OPCom Particle Monitor.

- \* The exact determination of the cleanliness class is possible in a viscosity range of 15 mm<sup>2</sup>/s to 250 mm<sup>2</sup>/s / 70 SUS to 1160 SUS.
- \*\* Indications at 50 Hz. At 60 Hz the value increases by 20 %.
- \*\*\* H<sub>2</sub>O + OPCom Particle Monitor, function see description
- \*\*\*\* H<sub>2</sub>O+ II + OPCom Particle Monitor, function see description

Other versions on request.

### Filter elements:

see Selection Chart.

Water-absorbing filter elements EXAPOR®AQUA on request.

### Accessories:

Hose extensions on request.

For the appropriate clogging indicators see datasheet 60.20.