

## RACCORDI A PRESSARE

STANDARD

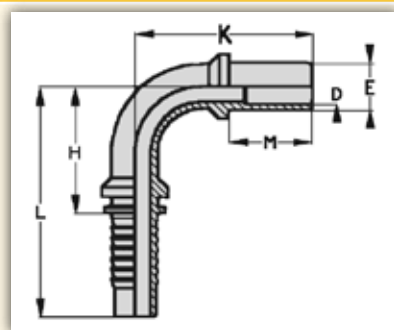

## ESTREMITÀ TUBOLARE 90°



| CODICE  | Diametro interno tubo |    | Diametro E<br>mm | Dimensioni mm |     |     |    |     |
|---------|-----------------------|----|------------------|---------------|-----|-----|----|-----|
|         | Pollici               | DN |                  | H             | L   | K   | M  | D   |
| EC03247 | 3/16"                 | 5  | 6                | 21            | 47  | 37  | 23 | 3   |
| EC03248 | 3/16"                 | 5  | 8                | 21            | 47  | 37  | 23 | 3   |
| EC042H4 | 1/4"                  | 6  | 6                | 24            | 52  | 39  | 21 | 4   |
| EC04247 | 1/4"                  | 6  | 8                | 24            | 52  | 39  | 23 | 4   |
| EC04248 | 1/4"                  | 6  | 10               | 24            | 52  | 42  | 25 | 4   |
| EC042H5 | 1/4"                  | 6  | 12               | 24            | 52  | 42  | 25 | 4   |
| EC05247 | 5/16"                 | 8  | 10               | 31            | 59  | 45  | 25 | 5   |
| EC05248 | 5/16"                 | 8  | 12               | 31            | 59  | 45  | 25 | 7   |
| EC062H4 | 3/8"                  | 10 | 10               | 34            | 64  | 48  | 22 | 7   |
| EC06247 | 3/8"                  | 10 | 12               | 34            | 64  | 48  | 25 | 7   |
| EC06248 | 3/8"                  | 10 | 14               | 34            | 64  | 52  | 28 | 7   |
| EC062H5 | 3/8"                  | 10 | 15               | 34            | 64  | 48  | 24 | 7   |
| EC082H4 | 1/2"                  | 13 | 14               | 41            | 74  | 57  | 29 | 9,5 |
| EC08247 | 1/2"                  | 13 | 15               | 41            | 74  | 53  | 25 | 9,5 |
| EC08248 | 1/2"                  | 13 | 16               | 41            | 74  | 58  | 30 | 9,5 |
| EC082H5 | 1/2"                  | 13 | 18               | 41            | 74  | 55  | 26 | 9,5 |
| EC10247 | 5/8"                  | 16 | 18               | 49            | 85  | 61  | 26 | 12  |
| EC10248 | 5/8"                  | 16 | 20               | 49            | 85  | 70  | 36 | 12  |
| EC102H4 | 5/8"                  | 16 | 22               | 49            | 85  | 60  | 28 | 12  |
| EC122H4 | 3/4"                  | 19 | 20               | 58            | 99  | 78  | 36 | 15  |
| EC12247 | 3/4"                  | 19 | 22               | 58            | 99  | 71  | 28 | 15  |
| EC12248 | 3/4"                  | 19 | 25               | 58            | 99  | 82  | 40 | 15  |
| EC162H4 | 1"                    | 25 | 25               | 74            | 129 | 92  | 40 | 20  |
| EC16247 | 1"                    | 25 | 28               | 74            | 129 | 82  | 30 | 20  |
| EC16248 | 1"                    | 25 | 30               | 74            | 129 | 96  | 44 | 20  |
| EC162H5 | 1"                    | 25 | 38               | 74            | 129 | 105 | 50 | 20  |
| EC202H4 | 1.1/4"                | 32 | 30               | 92            | 153 | 109 | 44 | 26  |
| EC20247 | 1.1/4"                | 32 | 35               | 92            | 153 | 101 | 36 | 26  |
| EC20248 | 1.1/4"                | 32 | 38               | 92            | 153 | 114 | 48 | 26  |
| EC242H4 | 1.1/2"                | 38 | 38               | 108           | 179 | 125 | 48 | 32  |
| EC24247 | 1.1/2"                | 38 | 42               | 108           | 179 | 113 | 36 | 32  |

I raccordi presenti in questa pagina sono fornibili anche in **ACCIAIO INOX AISI 316**  
 Il codice cambia alla quinta cifra come nell'esempio:

|    |    |   |    |
|----|----|---|----|
| EC | 08 | 2 | 01 |
| EC | 08 | 8 | 01 |

&gt; codice raccordo standard

&gt; codice stesso raccordo in acciaio inox AISI 316

