

T ORIENTABILE - MASCHIO JIC / MASCHIO UNF / MASCHIO JIC

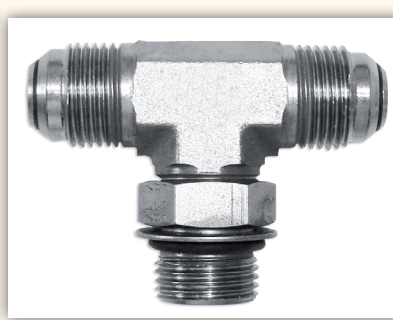

CODICE	Filettatura F1	Filettatura F2 *	Dimensioni mm		
			L	B	C
EFT38080C	7/16"-20	7/16"-20	45	22,5	26
EFT38181C	1/2"-20	1/2"-20	48	24	27,5
EFT38182C	9/16"-18	9/16"-18	54	27	31,5
EFT38484C	3/4"-16	3/4"-16	63	31,5	36,5
EFT38585C	7/8"-14	7/8"-14	73	36,5	43
EFT38686C	1.1/16"-12	1.1/16"-12	84	42	49
EFT38888C	1.5/16"-12	1.5/16"-12	92	46	52

* Maschio UNF sede piana con o-ring e rondella

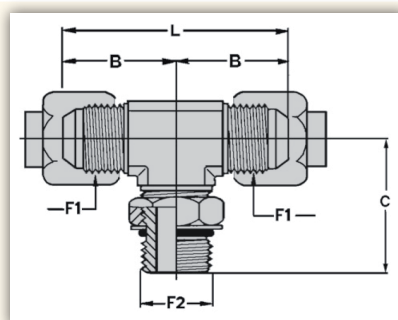

Filettature da 7/16"-20 a 7/8"-14
in accordo a UNF-2A

Filettature da 1.1/16"-12 a 1.7/8"-12
in accordo a UN-2A