

OGIVA A SALDARE CON DADO - GAS CILINDRICO

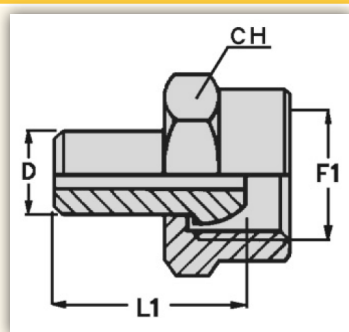

CODICE	Filettatura F1	Dimensioni mm		
		L1	D	CH
EF000SD04	1/4"	20	9	17
EF000SD06	3/8"	26	11,2	22
EF000SD08	1/2"	29	15,2	27
EF000SD10	5/8"	31	17,3	28
EF000SD12	3/4"	34	21,2	32
EF000SD16	1"	36	27,2	38
EF000SD20	1.1/4"	38	34,2	50
EF000SD24	1.1/2"	42	41,2	55
EF000SD32	2"	42	47,2	65