

MEZZO NIPLES A SALDARE - GAS CILINDRICO

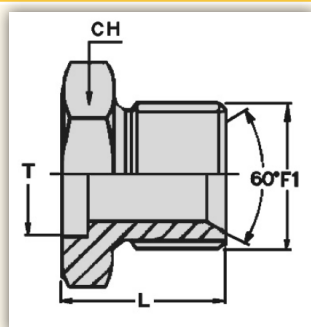

CODICE con tasca	CODICE senza tasca	Filettatura F1	Dimensioni mm		
			T	L	CH
EF000NS04	EFONSST04	1/4"	13,5	18	19
EF000NS06	EFONSST06	3/8"	17,2	21	22
EF000NS08	EFONSST08	1/2"	21,2	25	27
EF000NS10	EFONSST10	5/8"	22,2	26	27
EF000NS12	EFONSST12	3/4"	27,2	27	32
EF000NS16	EFONSST16	1"	34,2	30	41
EF000NS20	EFONSST20	1.1/4"	42,2	32	50
EF000NS24	-	1.1/2"	48,2	34	55
EF000NS32	-	2"	60,2	36	70