

ADATTATORE 90° - FLANGIA SAE / MASCHIO GAS CILINDRICO

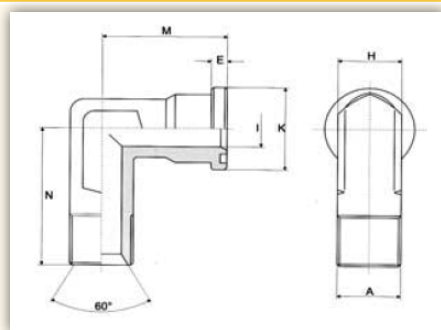

CODICE	Filettatura A	Flangia	K	E	I	M	N	Chiave H
	BSP	SAE	mm	mm	mm	mm	mm	mm
EF0GNF308	1/2"	3000 1/2"	30,2	6,7	12	44	50	22
EF0GNF312	3/4"	3000 3/4"	38,1	6,7	17	53	64	27
EF0GNF315	3/4"	3000 1"	44,4	8	17	60	65	34
EF0GNF316	1"	3000 1"	44,4	8	22	60	65	34
EF0GNF319	1"	3000 1.1/4"	50,8	8	22	55	64	42
EF0GNF320	1.1/4"	3000 1.1/4"	50,8	8	28	55	64	42
EF0GNF608	1/2"	6000 1/2"	31,8	7,7	12	44	50	22
EF0GNF612	3/4"	6000 3/4"	41,3	8,7	17	53	64	27
EF0GNF615	3/4"	6000 1"	47,6	9,5	17	60	62	34
EF0GNF616	1"	6000 1"	47,6	9,5	22	60	62	34
EF0GNF619	1"	6000 1.1/4"	54	10,3	22	70	72	42
EF0GNF620	1.1/4"	6000 1.1/4"	54	10,3	27	70	72	42
EF0GNF624	1.1/2"	6000 1.1/2"	63,5	12,5	32	80	84	50